

12

Adjectives

First and Second Declension Adjectives Morphology: The Nominal System (Part 7)

Lesson Twelve Overview

§12.0	Introduction, 12-1
§12.1	General Introduction to Adjectives, 12-2
§12.2	Introduction to Greek Adjectives, 12-7
§12.3	The verb ΕΙΜΙ, 12-37
§12.4	Adjective Flow Chart, 12-42
§12.5	Vocabulary Study, 12-43
Study Guide, 12-47	

§12.0 Introduction

Lessons six through eleven focused on nouns, specifically first and second declension nouns. Nouns name or designate a person, thing, or quality and form the nominal nucleus of a language. However, if it was not for another vital part of speech, the adjective, nouns would lack vividness as to definiteness, shape, size, quantity, color, and texture—words that describe nouns that otherwise would be general or bland.

Adjectives stimulate the mind to form indelible mental images about the state of a noun. They ascribe quality, quantity, and distinction to nouns. Without them, speech would be boring, reading dull, and the excitement drawn from the five senses non-descriptive. Indeed, it would be a dreary and monotonous world without adjectives.

Adjectives that modify nouns lend distinction to them. They are almost as important as their governing noun—if not as important. Consider the opening two lines of Edgar Allan Poe’s poem, *The Raven*.

Once upon a midnight *dreary*, while I pondered, *weak* and *weary*,
Over *many* a *quaint* and *curious* volume of *forgotten* lore,

If the adjectives, *a*, *dreary*, *weak*, *weary*, *many*, *quaint*, *curious*, and *forgotten* were removed and the stanza revised as “Once upon midnight, while I pondered, over volume of lore”, who would read it twice, much less quote it? Without the adjectives, the intense mood of despair is broken.

The power of the verses are defined by Poe’s literary genius of word choice and placement of the adjectives—“only this, and nothing more”.

§12.1 General Introduction to Adjectives

Adjectives are an important part of speech in English and Greek. Both languages abound with them and share certain traits. An overview concerning adjectives is first outlined with an emphasis upon how they function in English before comparing and contrasting their characteristics with those of Greek adjectives (cf. §12.2).

§12.11 Definition. Either in English and Greek, an adjective may modify a noun, pronoun, or a phrase used as a substantive, by describing or limiting as to quality, quantity, or definiteness.

When an adjective modifies a substantive, the adjective adds detail and specifies the substantive as something distinct from something else. For example, various adjectives can make the noun *dog* more specific. A *speckled* dog adds a quality. *This young small speckled Dalmatian* dog adds even more detail to differentiate it from possible other dogs.

An adjective is identified by its function or position in a sentence. Most adjectives can come between an article and a noun, and can stand singly before or after copulative verbs (*i.e.*, “is”, “am”, “are”, etc.). In addition, adjectives express degrees of comparison by function words (cf. §12.13).

As a part of speech in English, adjectives are usually single and occasionally hyphenated words (*i.e.*, one-eyed, know-it-all, long-term). However, expressions that roughly perform the same function are *adjectival phrases* and *adjectival clauses*. For example, in the *angry* man and the man *angered by her cruel behavior*, the clause *angered by her cruel behavior* modifies the noun man, just as the adjective *angry* does. Greek adjectival phrases and clauses will be studied in later lessons.

Many adjectives were originally nouns placed near other nouns to describe or otherwise limit their meaning, and gradually grew into a distinct class of words. This is true in both English and Greek. In fact, the Greek term for “adjective”, ὄνομα ἐπίθετον, appropriately describes their function as descriptive words or “epithets” that are adjunct to nouns.



The adjective is not the only method in Greek to describe a substantive. The same force belongs to a noun in the genitive case, especially the genitive of description and the genitive of apposition. These as well as other usages of the genitive will be explained in a later lesson.

§12.12 Function of adjectives. Adjectives may be identified according to their function in a sentence. The following three roles of adjectives are the classic categorization used in most grammars.

§12.121 Attributive. Most English adjectives occur before nouns: *large* house, *quick* lunch, *fun* time. These adjectives attribute a quality to nouns. These types of adjectives are **attributive**. An attributive adjective is always dependant upon the substantive it modifies. It never occurs by itself without its substantive. If an article modifies the noun, whether definite or indefinite, the attributive adjective is sandwiched between the two: a *hard* table, the *hot* poker. When an adjective precedes the noun, pronoun, or substantive it modifies, it is in the **attributive position**.

English attributive adjectives occasionally occur immediately after the noun for dramatic or more emphatic effect, but are not technically categorized as in the attributive position in English (*i.e.*, president *elect*, God *Almighty*, face *white* with fear, joy *unspeakable*, Kansas City *proper*).

§12.122 Predicative. Adjectives can also come before or follow a **copulative verb**. Copulative verbs include the verb *to be* and such verbs as *seem*, *become*, or *feel*, verbs that never take a direct object. In the sentence, “The bed is hard”, the adjective *hard* follows the copulative verb *is* and modifies the noun *bed*. With these verbs, the adjective supplies the predication about the noun; hence, **predicate adjectives**. Not only do they differ from attributive adjectives by their function in a sentence, but also in that no article is employed with them. Adjectives that are “coupled” to a noun with copulative verbs are in the **predicate position**.

Some predicate adjectives may precede a copulative verb, in which case, the subject then follows: “*Blessed* are the peacemakers”. Adjectives that follow nouns and repeat the meaning of the noun in different words are **adjective appositives**: The boring speech, *long* and *dull*, lasted forever!

Whatever positions an adjective sustain, whether attributive or predicative, it has the function of modifying by qualifying, limiting, identifying, or describing the meaning of the substantive with which it is connected.

§12.123 Substantive. Sometimes, adjectives may function as a substantive. In these instances, the adjective does not modify a noun but is itself a substantive as in “the *good* die young”, or “the *poor* you have always with you”. These adjectives are functioning **substantively**.

Substantival adjectives are not ascribed a position as attributive and predicate adjectives are, and their function in a sentence is indistinguishable from a substantive. The article normally precedes a substantival adjective.

§12.13 Degrees of comparison. Adjectives have three degrees of comparison, called the **positive**, the **comparative**, and the **superlative**. The positive degree expresses the quality of an object without reference to another object: “a *large* house”. The comparative degree shows that an object has more or less of a quality than some other object or objects with which it is compared: “a *larger* house”. The superlative degree expresses the greatest or least amount or intensity of a quality that is found among all the objects of a group compared: “the *largest* house”. The definite article usually accompanies the superlative degree of the adjective.

§12.131 Adjectives with one syllable. Most positive adjectives of one syllable add *-er* to form the comparative and *-est* to form the superlative, as shown in the following examples.

Positive	Comparative	Superlative
cold	colder	the coldest
warm	warmer	the warmest
wet	wetter	the wettest
dry	drier	the driest
low	lower	the lowest
high	higher	the highest
slow	slower	the slowest
fast	faster	the fastest

§12.132 Adjectives of more than one syllable. Adjectives with more than one syllable usually indicate differences in amount of degree by the addition of function words or by spelling changes. The function words “less” and “least” indicate decreasing amounts or degrees. The function words “more” and “most” show increasing amounts of degrees. These function words come before the positive to indicate the comparative and the superlative, respectively, as in the examples.

Positive	Comparative	Superlative
interesting	less interesting	the least interesting
	more interesting	the most interesting
accurate	less accurate	the least accurate
	more accurate	the most accurate
anxious	less anxious	the least anxious
	more anxious	the most anxious
honest	less honest	the least honest
	more honest	the most honest
lovely	less lovelier	the least loveliest
	more lovelier	the most loveliest

Many adjectives, including handsome, happy, lovely, and proud, may be compared by either method: happy, happier, happiest; or happy, more happy, most happy.

§12.133 Irregular adjectives. Few English adjectives indicate comparison by irregular forms. These forms follow no pattern and are a source of consternation for those learning English as a second language.

Positive	Comparative	Superlative
good	better	the best
bad	worse	the worst
many	more	the most
less	lesser	the least
late	later	the latest
far	farther, further	the farthest, furthest

§12.134 Absolute adjectives. Although most adjectives indicate three degrees of comparison, a few adjectives exist in only one degree (*unique*, *foremost*, and *perfect*, and the ordinal numerals [*i.e.*, *first*, *second*, *third*, etc.]) These are **absolute adjectives** and they do not permit comparison.

§12.14 Classification of Adjectives. Adjectives may be classified according to their function, attributing quality, quantity, or as a determiner, answering the questions “What kind of?”, “How much?”, and “Which” or “What?” respectively.

The chart below shows these general classifications of adjectives with a few subcategories. Although these broad classifications could be further subdivided into more subcategories, it is not necessary for this overview.

Definition and Examples	
Classification	<p>Quality “What kind of?”</p> <p>Denotes quality that is descriptive and specifies the kind, nature, or condition of the words they modify. Among others, adjectives of this category describe material, spatial, possibility, necessity, and proper. The proper adjective is always written with a capital letter.</p> <p>Subjective: <i>beautiful</i> woman, <i>young</i> man, <i>bad</i> choice</p> <p>Objective: <i>black</i> dog, <i>red</i> house, <i>unique</i> quality</p> <p>Proper: <i>French</i> cuisine, <i>American</i> flag</p>
	<p>Quantity “How much?”</p> <p>Limits substantives to their quantity or number.</p> <p><i>thirty</i> cents, a <i>six-year-old</i> child, <i>many</i> trees, <i>few</i> goldfish</p>
	<p>Determiner “Which?” “What?”</p> <p>Place limits on a noun rather than add description. Several groups of words serve as determiners, including the article, possessive, demonstrative, indefinite, and interrogative pronouns.</p> <p>Article: <i>a</i> boy, <i>an</i> addendum, <i>the</i> girl</p> <p>Possessive: <i>his</i> book, <i>her</i> toy, <i>my</i> kite</p> <p>Demonstrative: <i>this</i> computer, <i>that</i> album, <i>these</i> books</p> <p>Indefinite: <i>some</i> food, <i>several</i> coins</p> <p>Interrogative: <i>Which</i> ones? <i>What</i> are the costs?</p>

We are now ready to turn our attention specifically to Greek adjectives.

§12.2 Introduction to Greek Adjectives

The fundamental aspects of English adjectives correlate to Greek adjectives, specifically in definition (§12.11), function (§12.12), degrees of comparison (§12.13), and classification (§12.14). However, there are particular aspects of Greek adjectives that deserve special attention.

§12.21 Grammatical concord. *When an adjective functions adjectivally, it agrees with the substantive it modifies in case, gender, and number.*

Adding adjectives to an English sentence is straightforward. Whether adding adjectives to describe men, women, or inanimate objects like books or trees, they all could be described as “good”. An English adjective may be put next to any substantive it modifies, and the adjective does not change form to conform to the substantive’s case, gender, and number because the adjective is not inflected to agree with its substantive.

In Greek, however, such simplicity is not possible because of inflection. Like the substantives they modify, adjectives are an inflected part of speech. Greek adjectives are inflected for each of the five cases, the three genders, and the two numbers. This makes it possible for any adjective to agree in grammatical concord with the substantive it modifies in case, gender, and number—like the article.

The good news is that, because Greek adjectives decline like nouns, there are not any new case-number forms to learn. The bad news is that, like the article, they do not always reflect the same declensional ending as the noun they modify. Let us look at a few examples of adjectives modifying nouns and see why.

1. In the first example, the stem for the adjective ἀγαθός is ἀγαθο.

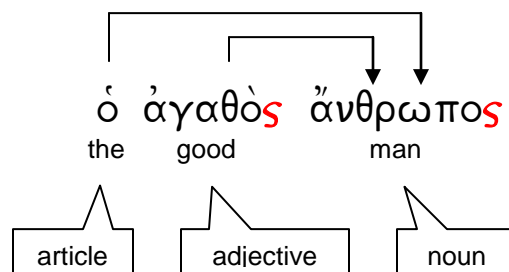

The directional arrows indicate that both the article and the adjective modify the noun and agree with it in case, gender and number.

Because of grammatical concord, the adjective ἀγαθός must agree in case, gender, and number with its substantive, ἄνθρωπος (nominative masculine singular). Therefore, the adjective is inflected in its nominative, masculine singular form to agree with its substantive. In this instance, the adjective replicates the declensional ending of its substantive.



Like words that are adjectives, the article functions as an adjective and must agree with the substantive it modifies because of grammatical concord. Grammatical concord must be maintained at all times in a language that is inflected.

2. In the next example, the stem again for the adjective ἀγαθός is ἀγαθο.

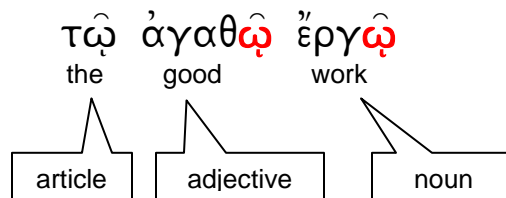

Again, because of grammatical concord, the adjective ἀγαθῷ must agree in case, gender, and number with its substantive, ἔργῳ (dative neuter singular). Therefore, the adjective is inflected in its dative neuter singular form to agree with its substantive. Once again, both the adjective and substantive have identical declensional endings.

3. In the next example, the stem for the adjective ἀγαθός is ἀγαθη.

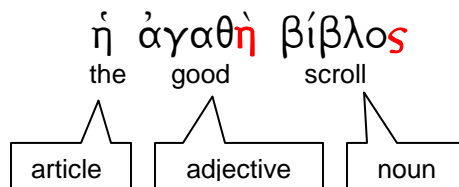

Because the substantive βίβλος (n-2b) is nominative feminine singular, its modifying adjective has to agree in case, gender, and number—and it does, although it may not look like it! The reason why the adjective does not appear to modify correctly its substantive is that the declensional ending of ἀγαθὴ is first declension and the substantive it modifies βίβλος is a second declension feminine noun that replicates masculine case-number declensional endings.

4. In the final example, the stem for the adjective ἀγαθός is ἀγαθο.

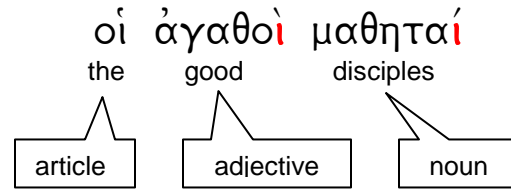

This example is the reverse of the one above. The substantive is a first declension nominative masculine plural noun, modified by a second declension adjectival form. In this instance, the inflected suffixes -οι and -αι are in grammatical concord, although they differ in both spelling and pronunciation.

In examples three and four, a common difficulty arises when trying to reconcile grammatical concord and phonetic dissonance. This is because adjectives of a different declension are modifying nouns that do not share the same inflected declensional endings. However, this is not any different from Greek articles modifying nouns of divergent phonetic dissonance. Consider the following examples.

1. ἡ ὁδός, τῆς ὁδοῦ, τῇ ὁδῶ, αἱ ὁδοί, ταῖς ὁδοῖς
2. τῶ νεανία, οἱ νεανίαι, τοῖς νεανίαις, τοὺς νεανίας
3. τῶ μαθητῇ, οἱ μαθηταί, τοῖς μαθηταῖς, τοὺς μαθητάς

What is the solution of overcoming phonetic dissonance when grammatical concord is not apparent because of cross-declension agreement? Without exception, know the gender of every noun without hesitation.

Those whose native language is largely uninflected like English cannot truly appreciate from the outset the significance of knowing a noun's gender in a highly inflected language like Greek. The Greek noun is the focal point of the nominal system, around which all other words that modify it must agree in case, gender, and number. Knowing the gender of a noun will clarify possible misunderstandings that might arise because of translation ambiguity.

For example, in Matthew 26:27, the King James Version reads, "Drink ye all of it." Did Jesus command each of His disciples to drink the entire cup?

If this was the case, after the first disciple drank, the next disciple would not have anything to drink, since they were sharing the same cup. The adjective “all” is nominative masculine plural and modifies the subject of the verb “drink”; the adjective cannot modify the cup. Therefore, the only possible meaning in Greek is “All of you drink from it.” However, one would not know this authoritatively without knowing that the adjective was modifying the subject of the sentence, and not the cup.

§12.22 Function of Greek adjectives. Like English adjectives, Greek adjectives may be identified according to their function in a sentence. Like English, Greek adjectives have one of three functions: it may have an attributive relation to a noun; it may have a predicative relation to a noun; or it may function substantively as though it were itself a noun.

Because Greek word order is more flexible than in English, inflection allows adjectives freer word order and therefore may appear in unexpected places than anticipated in English.

§12.22.1 Attributive. A Greek adjective may function attributively with or without the article. The attributive adjective, however, is *always* articular if an article occurs in the construction. Attributive adjectives occur in both the singular and plural numbers, in all three genders, and in all five cases.

§12.22.11 First attributive position. The usual word order that an adjective sustains in Greek is the same as the student is familiar with English: article-adjective-substantive.

- | | |
|---------------------------------------|--------------------------------------|
| 1. ὁ ἀγαθὸς ἄνθρωπος
the good man | οἱ ἀγαθοὶ ἄνθρωποι
the good men |
| 2. ἡ ἀγαθὴ καρδία
the good heart | αἱ ἀγαθαὶ καρδίαι
the good hearts |
| 3. τὸ ἀγαθὸν ἔργον
the good work | τὰ ἀγαθὰ ἔργα
the good works |
| 4. τῆς ἀγαθῆς ὁδοῦ
of the good way | τῶν ἀγαθῶν ὁδῶν
of the good ways |

An adjective in the **first attributive position** is immediately preceded by the article and both precede the *anarthrous* substantive. Some grammarians also call this adjective's position *ascriptive restrictive*. Translation follows sentence order.

§12.22.12 Second attributive position. Not as common as the previous construction, another attributive construction is article-substantive article-adjective. The word order is crucial—both the substantive and the adjective are articular, and the substantive precedes the adjective.

1. ὁ νόμος ὁ ἀγαθός
the law the good one

Translation: the good law

οἱ νόμοι οἱ ἀγαθοί
the laws the good ones

Translation: the good laws

2. ἡ βίβλος ἡ ἀγαθή
the scroll the good one

Translation: the good scroll

αἱ βίβλοι αἱ ἀγαθαί
the scrolls the good ones

Translation: the good scrolls

3. τὴν ὥραν τὴν πρώτην
the hour the first one

Translation: the first hour

τὰς ὥρας τὰς πρώτας
the hours the first ones

Translation: the first hours

4. τοῦ δώρου τοῦ καινοῦ
of the gift the of new one

Translation: of the new gift

τῶν δώρων τῶν καινῶν
of the gifts the of new ones

Translation: of the new gifts

The reverse construction, article-adjective article-substantive, does not occur in NTGreek.

~~ὁ ἀγαθὸς ὁ ἄνθρωπος~~

An adjective in the **second attributive position** is immediately preceded by the article and both follow the *articular* substantive. Some grammarians also call this adjective's position *restrictive attributive*.

A possible difference in emphasis between first and second attributive position adjectives is suggested by some Greek grammarians. Some posit that the second attributive adjective is somewhat more emphatic in word order than the first because of its post-position articular construction.

It is my personal observation, however, that authors with a Semitic background (*i.e.*, the Apostle John) are more likely to employ the second attributive position than the first. Therefore, just because an author uses the adjective in the second attributive position may not convey emphasis if it is their normal literary style. Care must be exercised to examine an author's stylistic predictability before making an assertion that one position is more emphatic than another. Otherwise, possible theological inaccuracies may develop because of faulty exegesis.

§12.22.13 Third attributive position. The third and final articular attributive position is rarely found in NTGreek: noun article-adjective.

1. εἰρήνην τὴν ἐμὴν John 14:27

Translation: my peace

2. Ἐπαίνετον τὸν ἀγαπητόν μου Romans 16:5

Translation: Epenetus [my] beloved [friend]

3. Γαίῳ τῷ ἀγαπητῷ 3 John 1

Translation: to Gaius [my] beloved [friend]

4. Βαβυλῶν ἡ μεγάλη Revelation 18:2

Translation: Babylon the great

An adjective in the **third attributive position** is immediately preceded by the article and both follow the anarthrous substantive.

§12.22.14 Anarthrous attributive adjective. The last attributive adjective construction lacks an article before both the substantive and adjective. This type of construction occurs occasionally in NTGreek. Adjectives that precede the substantive are pre-positive, and those that follow are postpositive. Most anarthrous adjectives are postpositive.

The following examples illustrate the anarthrous attributive adjective in both pre-positive and postpositive positions. Regardless of position, the translation is identical.

<p>1. ἄνθρωπος ἀγαθός Translation: good man</p>	<p>ἀγαθὸς ἄνθρωπος Translation: good man</p>
<p>2. ἄνθρωπος ἁμαρτωλός Translation: sinful man</p>	<p>ἁμαρτωλὸς ἄνθρωπος Translation: sinful man</p>
<p>3. καρπὸς καλός Translation: good fruit</p>	<p>καλὸς καρπός Translation: good fruit</p>
<p>4. διδάσκαλε ἀγαθέ Translation: good teacher</p>	<p>ἀγαθὲ διδάσκαλε Translation: good teacher</p>

§12.22.15 Possible attributive adjective constructions. The possible different positions of the attributive adjective may vary, depending upon an author's desire of emphasis (if it varies from his predictable literary style).

	Sentence order	Translation
1.	ὁ ἀγαθὸς ἀπόστολος	The good apostle (1 st attributive)
2.	ὁ ἀπόστολος ὁ ἀγαθός	The good apostle (2 nd attributive)
3.	εἰρήνην τὴν ἐμὴν	my peace (3 rd attributive)
4.	ἀπόστολος ἀγαθός	good apostle (anarthrous attributive)

§12.22.16 Important information about the attributive construction.

- 1. Position of the article.** The attributive adjective will be articular in most instances. However, if the article does not immediately precede the adjective, it is probably not an attributive adjective. Because of the nature of its construction, the anarthrous attributive adjective is at times confused with its predicative use (cf. §12.22.2). If the article immediately precedes the adjective, its usage is generally attributive or substantive; if the adjective is anarthrous, it is predicative (especially when a substantive is present).
- 2. Grammatical concord.** The adjective agrees with the explicit substantive it modifies in case, gender, and number.

3. **Emphasis.** The second attributive position is: article-noun-article-adjective. The difference in the placement of the adjective is of position. In this structure, both the substantive and adjective receive emphasis. The adjective follows the noun in a climactic position with its own article. A literal translation that brings out the force is "the word, the good one". However, caution must be exercised, because the author's style must be examined before emphasis can be determined.
4. **Translation.** Regardless whether the adjective is pre-positive or postpositive, the translation is identical in English.

§12.22.2 Predicative. In contrast to the attributive adjective, an adjective may also be used as the complement of a **copulative verb** such as εἶμι ("I am"). Copulative verbs are also called **linking** or **equative** verbs by some grammarians. The distinctive feature concerning copulative verbs is that they never take a direct object, but instead, make an affirmation about the substantive it modifies, functioning as an equal sign (=) between the substantive and the adjective.

An adjective functions predicatively only when it meets three criteria: (1) the adjective is anarthrous, (2) the presence of an explicit or implicit substantive (with or without the article), and (3) the construction includes a copulative verb. However, unlike English, a copulative verb does not have to be explicit in a Greek predicate construction. The omission of the copulative verb does not compromise the force of the predicate adjective.

- | | |
|-------------------------------|-------------------------------|
| 1. ὁ λόγος ἐστὶν ἀγαθός | ἀγαθὸς ἐστὶν ὁ λόγος |
| Translation: the word is good | Translation: the word is good |
| 2. ὁ λόγος ἀγαθός | ἀγαθὸς ὁ λόγος |
| Translation: the word is good | Translation: the word is good |
| 3. λόγος ἀγαθός | ἀγαθὸς λόγος |
| Translation: word [is] good | Translation: word [is] good |

§12.22.21 Possible predicate adjective constructions. The possible different positions of the predicate adjective may vary, depending upon an author's desire of emphasis (if it varies from his predictable literary style).

Examples 1, 3, 5, and 8 lend emphasis to the substantive, whereas emphasis is on the adjective in examples 2, 4, 6, and 7. Because of inflection, Greek can make distinctions in the use of adjectives that are impossible to reflect in uninflected languages, being translated the same because of the language's inflexible sentence order.

	Sentence order	Translation
1.	ὁ ἀπόστολος ἐστὶν ἀγαθός.	The apostle is good.
2.	ἀγαθὸς ἐστὶν ὁ ἀπόστολος.	The apostle is good.
3.	ἀπόστολος ἐστὶν ἀγαθός.	Apostle is good.
4.	ἀγαθὸς ἐστὶν ἀπόστολος	Apostle is good.
5.	ὁ ἀπόστολος ἀγαθός.	The apostle [is] good.
6.	ἀγαθὸς ὁ ἀπόστολος.	The apostle [is] good.
7.	ἀγαθὸς ἀπόστολος.	Apostle [is] good.
8.	ἀπόστολος ἀγαθός.	Apostle [is] good.

§12.22.22 Important information about the predicative construction.

1. **Position of the article.** The article never immediately precedes the predicate adjective. However, Greek syntax allows the adjective to be placed before or after an anarthrous or articular substantive—but never between the article (if present) and the substantive it modifies. In other words, the article does not determine the relation of the adjective to the noun, but the manner by which the adjective characterizes the noun: whether the adjective is incidental (attributive) or significant (predicative) in the statement.
2. **Attributive versus Predicative.** The larger context determines when an adjective is functioning attributively or predicatively. For example, if ἀγαθὸς λόγος stands alone as a complete sentence, the adjective functions predicatively. However, in a sentence that contains a verb other than a copulative verb, the adjective functions attributively. An attributive adjective generally is articular in NTGreek—but not always! Most anarthrous noun and adjective combinations are attributive.

3. **Presence of the copulative verb.** NTGreek authors typically used the copulative verb with the predicative adjective construction. Nevertheless, it is still important to understand the difference between the attributive and predicative positions in instances where there is no copulative verb to help distinguish between the two.

With the introduction of predicate adjectives, the boundary between substantives and verbs has been breached. The common occurring copulative verb, εἰμί (“I am”) in predicate constructions will receive special attention in §12.3.

4. **Grammatical concord.** As with the attributive adjective, the predicative adjective agrees with the substantive it modifies in case, gender, and number. However, grammatical concord does not necessarily signify that predicative adjectives have the same declensional suffixes as their substantive, although this frequently happens. As with attributive adjectives, cross-declension phonetic dissonance occurs.
5. **Translation.** When an adjective is in the predicate position but the construction lacks the copulative verb, the English translation should reflect the ellipsis by indicating it between brackets [] to differentiate it from the attributive adjective. However, it is inaccurate to say that a Greek verb is “understood” in such constructions. Whereas the English translation is required to supply the copulative verb, Greek is not under any such restraint. Furthermore, if the substantive lacks the article, the English translation should not include the article unless demanded by context, and then only in brackets.
6. **Emphasis.** The predicate adjective construction is more emphatic than the simpler attributive adjective. Whereas the attributive relation ascribes a quality to the substantive which it modifies, the predicate relation makes an assertion, an affirmation with the help of the copulative verb. The predicate adjective is often further elaborated in the immediate context, whereas the attributive adjective seldom is. A. T. Robertson summarizes the matter by saying that “the predicate presents an additional statement, is indeed the main point, while the attributive is an incidental description of the substantive about which the statement is made” (*Grammar of the Greek New Testament*, p. 656).

§12.22.3 Substantive. An adjective functions substantively when it functions as a substantive. This function of the adjective is called the **substantival adjective**. It occurs in all cases, genders, and numbers.

The substantival adjective is usually preceded by the article, although not necessarily immediately (*i.e.*, ὁ τοῦ κόσμου σοφός). The same construction occurs in English expressions like “the dead will rise”. The adjective “dead” substitutes for an implicit noun derived from the larger context. Hence, a substantive adjective functions the same as an attributive adjective except that the noun it modifies is supplied by its context rather than expressed. The gender of the substantive adjective will indicate the gender of the substantive it replaces, as follows:

- | | |
|------------------------------------|-------------------------------------|
| 1. ὁ ἀγαθός | οἱ ἀγαθοί |
| Translation: “the good [man]” | Translation: “the good [men]” |
| 2. τὴν ἀγαθὴν | τὰς ἀγαθὰς |
| Translation: “the good [woman]” | Translation: “the good [women]” |
| 3. τοῦ ἀγαθοῦ | τῶν ἀγαθῶν |
| Translation: “of the good [thing]” | Translation: “of the good [things]” |

§12.231 Important information about the substantival adjective.

1. In Greek, substantival adjectives are considerably more common than in English. For all practical purposes, the substantival adjective could have been introduced when nouns were studied because of their identical syntactical use in a phrase, clause, or sentence.
2. The substantival adjective regains its original usage when it functions as a substantive. Originally, no distinction was made between them. Because of usage over time, a distinction was made between the two parts of speech. The same phenomenon appears in English in the sentences, “They are red *boxes*” and “They are *box cars*”. In the first instance, the word “box” functions as a substantive, whereas in the latter, an adjective. You can identify the adjective when an “s” or “es” cannot be added to an English adjective and make sense, since English adjectives are not inflected for either the

singular or plural. An interesting development in English is to compare the adjective “good” with the substantive, “the goods”.

3. The Greek adjective is a specialized use of the noun—or what used to function principally as a noun (cf. Dana and Mantey, *A Manual Grammar of the Greek New Testament*, pp. 115-116). The term “noun” is used by many grammarians to designate both substantives and adjectives. As one grammarian states the matter, there are “two sorts of nouns, substantive and adjective” (Winer, 234). This close relationship is evidenced by the following points:
 - a. The close affinity between the noun and the adjective in stem and inflection. Adjective stems are based upon first, second, and third declension nouns. The adjective inflects according to case, gender, and number.
 - b. The adjective may be modified by the article just as any substantive. Recognizing the article before a substantival adjective will many times give an important insight as in Matthew 6:13: ῥύσαι ἡμᾶς ἀπὸ τοῦ πονηροῦ (“deliver us from the evil one”). Because the form of πονηροῦ may be neuter or masculine, it is indecisive whether it refers to evil in general or masculine, and therefore to Satan. Jesus, however, equates τοῦ πονηροῦ with ὁ διάβολος in Matthew 13:38-39. Therefore, Jesus is teaching His disciples to request that the Father deliver them from “the evil one”, and not from evil in general (cf. KJV).
 - c. A substantive may function appositionally in the exact relation of an adjective, as in τῷ Ἰορδάνῃ ποταμῷ (“in the Jordan river”). Normally, “Jordan” (Ἰορδάνης, -ου, ὅ) is used as a proper noun. However, in Matthew 3:6, it is functioning as a proper adjective. Thus, in its function, an adjective is an outgrowth of a noun used in a qualifying relationship with another noun.

A clear distinction between an adjective and a substantive, however, is that a substantive’s gender remains constant throughout its inflection, whereas the adjective does not, which is reflected in its lexical entry (cf. §12.25).

Other matters concerning Greek adjectives such as comparison and its use as an adverb will be addressed in later lessons.

§12.24 Summary of adjectival constructions.

Function	Explanations and Examples
ATTRIBUTIVE	An adjective may function attributive and modify the substantive by attributing, ascribing, restricting a quality or quantity of a substantive, with or without the article.
Articular	Article may occur with the attributive adjective.
First	ὁ ἄγαθὸς λόγος (frequent; style or emphatic)
Second	ὁ λόγος ὁ ἄγαθός (occasional; style or emphatic)
Third	Γαίῳ τῷ ἀγαπητῷ (rare)
Anarthrous	Article may not occur with the attributive adjective.
Pre-position	ἀγαθὸς ἄνθρωπος (occasional)
Postposition	ἄνθρωπος ἀγαθός (frequent)
PREDICATIVE	Adjectives may function predicatively to make an assertion or statement about, or indicate some quality, quantity, or characteristic of the articular or anarthrous substantive. A linking verb is implicit or explicit.
Articular	The article may occur with the <u>substantive</u> .
Pre-position	ἀγαθὸς ἐστὶν ὁ λόγος. (style or emphatic)
Postposition	ὁ λόγος ἐστὶν ἀγαθός. (typical construction)
Anarthrous	Article may not occur with the <u>substantive</u> . Because of the anarthrous construction, it may be confused with the attributive usage.
Pre-position	καλοὺς καρπούς. (possible emphasis)
Postposition	καρπούς καλούς.
SUBSTANTIVE	Adjectives frequently function as a substantive, whether or not the substantive adjective is articular.
Articular	Substantive adjective is usually articular.
Singular	ὁ ἄγαθὸς βλέπει τὸν ἀπόστολον.
Plural	οἱ ἄγαθοὶ βλέπουσι τὸν ἀπόστολον.
Anarthrous	Substantive adjective is sometimes anarthrous.
Singular	ἀγαθὸς βλέπει τὸν ἀπόστολον.
Plural	ἀγαθοὶ βλέπουσι τὸν ἀπόστολον.

§12.25 Lexical entry for adjectives. The lexical entry for adjectives is different from nouns. Adjectives may be recognized in a Greek-English lexicon because of the following criteria:

1. Since adjectives are inflected in all three genders, the primary lexical entry is its nominative masculine singular form, and not simply the nominative singular.
2. Unlike nouns, adjectives do not have the genitive singular as part of their lexical entry (cf. §6.2.21). The genitive singular establishes a noun's declension-paradigm; a more general criterion establishes an adjective's declension-paradigm (cf. §§12.26.21, 12.26.22).
3. The article is not part of an adjective's lexical entry since adjectives are declined in all three genders and not just one gender like most nouns.
4. Because adjectives are inflected in the masculine, feminine, and neuter, the lexical entry first cites the nominative masculine singular, followed by the feminine and neuter singular abbreviated endings. These forms are usually in boldface type.

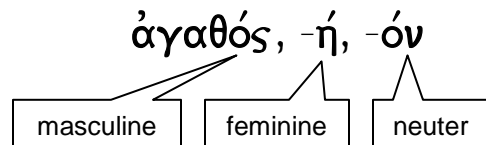

5. However, not all lexical entries for adjectives are identical. Some adjectives share masculine and feminine inflection, like second declension masculine (n-2a) and feminine (n-2b) nouns. In these instances, the lexical entry for the adjective is its nominative masculine/feminine form, with the neuter following.



When only two forms of an adjective are cited in a lexicon, it signifies that the masculine and feminine adjectival forms share endings.

Adjectives that are identical in their masculine and feminine endings are called **two-terminal adjectives**. Adjectives that have a separate feminine inflection such as ἀγαθός are **three-terminal adjectives**. Approximately eighty-five percent of first, second, and third declension NTGreek adjectives are three-terminal adjectives, and therefore will have twenty-four forms (like the article).

There are no fixed rules to predict whether an adjective will have two or three terminations. In every instance, a lexicon will have to be consulted. Some adjectives also vary between two and three terminations. However, adjectives whose initial lexical forms terminate in -ος and negated by the **alpha privative** are always a two-terminal adjective (*i.e.*, ἄπιστος, -ον; πιστός, -ή, -όν).



Second declension feminine nouns (n-2b) are inflected identically to masculine nouns (n-2a). The same is true for two-terminal adjectives. There are also third declension adjectives which will be introduced after third declension nouns are studied.

6. The lexicon cites the type and position of accent for every adjective (cf. §12.27).
7. Adjectives are listed in alphabetical order in a Greek-English lexicon according to their masculine nominative singular form.

§12.26 First and second declension adjective classification.

Adjectives may be classified by the inflectional patterns employed in declining them. A first and second declension adjective uses inflectional forms from both the first and second declensions.

Adjectives that are two-terminal use the masculine-feminine and neuter endings like second declension nouns, while three-terminal adjectives additionally decline feminine adjectives using forms from the first declension. In any case, no additional endings are required to be learned for first and second declension adjectives.

§12.26.1 First and second declension adjective stem vowel. The stem vowel for two-terminal adjectives is *omikron* and follows inflectional patterns of second declension nouns. Just as with first declension

feminine nouns, no stem vowels are employed for feminine three-terminal adjectives. Their paradigms are declined like feminine nouns whose nominative singular ends with either *alpha* (n-1a) or *ēta* (n-1b). There are not any adjectival hybrid feminine patterns (n-1c) found in NTGreek.

§12.26.2 First and second declension adjectival paradigms. First and second declension adjectival paradigms may be distinguished if they are either a two-terminal or three-terminal adjective. The first adjective paradigm presented is a two-terminal adjective.

§12.26.21 Two-terminal adjective paradigm. The full adjective paradigm is cited, though masculine and feminine adjectives are identical.

ἁμαρτωλός, -όν (sinful) ἁμαρτωλο + case ending

Singular			
	a-2a	a-2b	a-2c
	Masculine	Feminine	Neuter
Nominative	ἁμαρτωλός ^ς	ἁμαρτωλό ^ς	ἁμαρτωλό ^ν
Genitive	ἁμαρτωλοῦ ^ῶ	ἁμαρτωλοῦ ^ῶ	ἁμαρτωλοῦ ^ῶ
Dative	ἁμαρτωλῶ ^ῶ	ἁμαρτωλῶ ^ῶ	ἁμαρτωλῶ ^ῶ
Accusative	ἁμαρτωλό ^ν	ἁμαρτωλό ^ν	ἁμαρτωλό ^ν
Vocative	ἁμαρτωλέ ^ς or ἁμαρτωλό ^ς	ἁμαρτωλέ ^ς or ἁμαρτωλό ^ς	ἁμαρτωλό ^ν

Plural			
	a-2a	a-2b	a-2c
	Masculine	Feminine	Neuter
Nominative	ἁμαρτωλοί ^ς	ἁμαρτωλοί ^ς	ἁμαρτωλά ^ς (short)
Genitive	ἁμαρτωλῶ ^ν	ἁμαρτωλῶ ^ν	ἁμαρτωλῶ ^ν
Dative	ἁμαρτωλοῖ ^ς	ἁμαρτωλοῖ ^ς	ἁμαρτωλοῖ ^ς
Accusative	ἁμαρτωλοῦ ^ς	ἁμαρτωλοῦ ^ς	ἁμαρτωλά ^ς (short)
Vocative	ἁμαρτωλοί ^ς	ἁμαρτωλοί ^ς	ἁμαρτωλά ^ς (short)

§12.26.211 Morphological observations. It will be observed that two-terminal second declension adjective inflections are identical to second declension inflected nouns. This means what was true for second declension masculine noun morphology is also true for second declension two-terminal adjectives (cf. §§6.2.211; 6.2.221; 6.2.231; 6.2.241; 6.2.251).

§12.26.22 Three-terminal adjective paradigm. Three-terminal first and second declension adjectives are like two-terminal adjectives, except they distinguish between the masculine and feminine forms.

1. When the next to the last letter of the feminine stem terminates with a vowel (*i.e.*, ε, ι) or *rhō*, the feminine singular will be *alpha*.

ἅγιος, -α, -ον (holy, sacred) ἅγιο/α + case ending

	Singular		
	a-2a	a-1a	a-2c
	Masculine	Feminine	Neuter
Nominative	ἅγιος	ἁγία	ἅγιον
Genitive	ἁγίου	ἁγίας*	ἁγίου
Dative	ἁγίῳ	ἁγίᾳ	ἁγίῳ
Accusative	ἅγιον	ἁγίαν	ἅγιον
Vocative	ἅγιε or ἅγιος	ἁγία	ἅγιον

	Plural		
	a-2a	a-1a	a-2c
	Masculine	Feminine	Neuter
Nominative	ἅγιοι	ἁγίαι	ἅγια (short)
Genitive	ἁγίων	ἁγίων	ἁγίων
Dative	ἁγίοις	ἁγίαις	ἁγίοις
Accusative	ἁγίους	ἁγίας*	ἅγια (short)
Vocative	ἅγιοι	ἁγίαι	ἅγια (short)

ἕτερος, -α, -ον (other [of a different kind]) ἕτερο/α + case ending

Singular			
	a-2a	a-1a	a-2c
	Masculine	Feminine	Neuter
Nominative	ἕτερος	ἑτέρα	ἕτερον
Genitive	ἑτέρου	ἑτέρας*	ἑτέρου
Dative	ἑτέρῳ	ἑτέρῃ	ἑτέρῳ
Accusative	ἕτερον	ἑτέρα	ἕτερον
Vocative	ἕτερε or ἕτερος	ἑτέρα	ἕτερον

Plural			
	a-2a	a-1a	a-2c
	Masculine	Feminine	Neuter
Nominative	ἕτεροι	ἑτεραι	ἑτερα (short)
Genitive	ἑτέρων	ἑτέρων	ἑτέρων
Dative	ἑτέροις	ἑτέραις	ἑτέροις
Accusative	ἑτέρους	ἑτέρας*	ἑτερα (short)
Vocative	ἕτεροι	ἑτεραι	ἑτερα (short)

* Notice that the genitive singular and accusative plural inflected endings replicate, just like their noun inflectional counterparts.

2. When the next to the last letter in the stem terminates with anything but a vowel or *rhō*, the feminine singular will be *ēta*.

This rule determines whether an adjective ending in *-ας* could be either genitive singular or accusative plural. For example, the form *ἀγίας* could be either genitive singular or accusative plural. However, adjectives whose nominative feminine singular terminates with *ēta* as *ἀγαθή* are distinguished in its genitive singular (*ἀγαθῆς*) and accusative plural (*ἀγαθάς*) forms.

ἀγαθός, -ή, -όν (good) ἀγαθο/η + case ending

Singular			
	a-2a	a-1b	a-2c
	Masculine	Feminine	Neuter
Nominative	ἀγαθός ^ς	ἀγαθή	ἀγαθόν ^ν
Genitive	ἀγαθοῦ ^ῶ	ἀγαθῆ ^ς	ἀγαθοῦ ^ῶ
Dative	ἀγαθῶ ^ι	ἀγαθῇ ^ι	ἀγαθῶ ^ι
Accusative	ἀγαθόν ^ν	ἀγαθή ^ν	ἀγαθόν ^ν
Vocative	ἀγαθέ ^ε or ἀγαθός ^ς	ἀγαθή	ἀγαθόν ^ν

Plural			
	a-2a	a-1b	a-2c
	Masculine	Feminine	Neuter
Nominative	ἀγαθοί	ἀγαθαί	ἀγαθά ^α (short)
Genitive	ἀγαθῶ ^ν	ἀγαθῶ ^ν	ἀγαθῶ ^ν
Dative	ἀγαθοῖ ^ς	ἀγαθαῖ ^ς	ἀγαθοῖ ^ς
Accusative	ἀγαθοῦ ^ς	ἀγαθά ^ς	ἀγαθά ^α (short)
Vocative	ἀγαθοί	ἀγαθαί	ἀγαθά ^α (short)

§12.26.221 Morphological observations.

1. Like first declension feminine nouns, the inflected endings of adjectives are determined by phonology. This is the reason why if the next to the last letter of the feminine stem ends with a vowel (*i.e.*, ε, ι) or *rhō*, the feminine singular is *alpha*; otherwise, it is *ēta* (cf. §§8.3; 8.4).
2. Like first declension feminine nouns, the plural inflected endings for all feminine adjectives are identical.
3. Feminine genitive singular and accusative plural endings will be differentiated in three-terminal adjectives whose nominative feminine singular stem terminates with -η (*i.e.*, ἀγαθῆς, ἀγαθάς).



Whether an adjective is two-terminal or three-terminal is not determined by the declension-paradigm of the substantive it modifies. An adjective's inflectional ending is determined by the form of the adjective and not the substantive. All the adjective has to do is to maintain grammatical concord.

§12.27 First and second declension adjective accent. The rules of accent applied to first and second declension nouns are the same for first and second declension adjectives except that the special first declension rule which always puts the circumflex on the genitive plural does not apply to the adjective (δικαίων, not δικαίων; cf. §10.3.5).

§12.28 Parsing Adjectives. Adjectives are parsed in identical order as nouns. The following table compares the parsing of these parts of speech.

Noun		Adjective
ἄνθρώπου	Inflected form	ἀγαθῆς
genitive	Case	genitive
masculine	Gender	feminine
singular	Number	singular
ἄνθρωπος	Lexical form	ἀγαθός
n-2a	Declension-paradigm	a-1b
“of man/mankind”	Translation	“of good [woman]”

As illustrated above, this grammar follows the following order when parsing an adjective. The parsing order is identical to nouns.

1. Case (nominative, genitive, dative, accusative, and vocative)
2. Gender (masculine, feminine, and neuter)
3. Number (singular and plural)
4. Lexical form (always the nominative masculine singular form)
5. Declension-paradigm notation
 - a. Two-terminal: a-2a (masculine), a-2b (feminine), and a-2c (neuter)
 - b. Three-terminal adjectives: a-2a (masculine), a-1a or a-1b (feminine), and a-2c (neuter)
6. Translation of inflected form

§12.281 Guidelines. Few principles should help while parsing adjectives.

1. The lexical form of every adjective is the nominative masculine singular (like the article)—always. For example, the lexical form of the inflected adjective ἀγαθῆς is ἀγαθός, and not ἀγαθή.
2. Cite all possibilities when parsing an isolated adjective. For example, ἀγαθῶ could be dative masculine or neuter singular of ἀγαθός. In addition, without context, the declension-paradigm notation of ἀγαθῶ could be either a-2a (masculine) or a-2c (neuter).
3. Some flexibility may be exercised when isolated adjectives are parsed and then translated. In example #6 below, σοφόν may be either masculine or neuter in form. However, since wisdom is usually attributed to someone as “wise”, the translation “wise [man]” was chosen to indicate proper gender. In example #3, the translation could have been “of beautiful [ones]” to denote the neuter gender. Without context, translation should be kept as general as possible while realizing that other possibilities of translation exist.

§12.282 Adjectives parsed. Below are examples of parsed Greek adjectives. After learning this lesson’s vocabulary, return and use this table as an additional exercise. Cover the right-hand column with a piece of paper, and then parse the adjectives in the left-hand column. Uncover the answer in the right-hand column to check accuracy of parsing.

1.	ἀγαθῆς	gen. fem. sg. of ἀγαθός, a-1b, “of good [woman]”
2.	ἕτεροι	nom./voc. fem. pl. of ἕτερος, a-1a, “different [women]”
3.	καλῶν	gen. masc./fem./neut. pl. of καλός, a-2a/a-1b/a-2c, “of handsome/beautiful ones”
4.	σοφούς	acc. masc. pl. of σοφός, a-2a, “wise [men]”
5.	σοφῆν	acc. fem. sg. of σοφός, a-1b, “wise [woman]”
6.	σοφόν	acc. masc. sg. or nom/voc./acc. neut. sg. of σοφός, a-2a/c “wise [man/things]”
7.	ἁμαρτωλέ	voc. masc./fem. sg. of ἁμαρτωλός, a-2a/b, “[O] sinful [man/woman]”

8.	παλαιός	masc. nom./voc. sg. of παλαιός, a-2a, "old [man] or [O] old [man]"
9.	πιστῶν	gen. masc./fem./neut. pl. of πιστός, a-2a/a-1b/a-2c, "of faithful [men/women/ones]"
10.	πρῶτον	acc. masc. or nom./voc./acc. neut. sg. of πρῶτος, a-2a/c, "first [man/one]; [O] first [man/one]"

§12.29 Vocabulary paradigms. Some of the lesson's adjective vocabulary words are declined below for illustrative purposes. Notice that the final *alpha* in all neuter plural forms is always short.

ἀγαθός, -ή, -όν (good) ἀγαθο/η + case ending

	Singular		
	a-2a	a-1b	a-2c
	Masculine	Feminine	Neuter
Nominative	ἀγαθός	ἀγαθή	ἀγαθόν
Genitive	ἀγαθοῦ	ἀγαθῆς	ἀγαθοῦ
Dative	ἀγαθῶ	ἀγαθῇ	ἀγαθῶ
Accusative	ἀγαθόν	ἀγαθήν	ἀγαθόν
Vocative	ἀγαθέ or ἀγαθός	ἀγαθή	ἀγαθόν

	Plural		
	a-2a	a-1b	a-2c
	Masculine	Feminine	Neuter
Nominative	ἀγαθοί	ἀγαθαί	ἀγαθά (short)
Genitive	ἀγαθῶν	ἀγαθῶν	ἀγαθῶν
Dative	ἀγαθοῖς	ἀγαθαῖς	ἀγαθοῖς
Accusative	ἀγαθοὺς	ἀγαθάς	ἀγαθά (short)
Vocative	ἀγαθοί	ἀγαθαί	ἀγαθά (short)

ἀγαπητός, -ή, -όν (beloved) ἀγαπητο/η + case ending

	Singular		
	a-2a	a-1b	a-2c
	Masculine	Feminine	Neuter
Nominative	ἀγαπητός	ἀγαπητή	ἀγαπητόν
Genitive	ἀγαπητοῦ	ἀγαπητῆς	ἀγαπητοῦ
Dative	ἀγαπητῷ	ἀγαπητῇ	ἀγαπητῷ
Accusative	ἀγαπητόν	ἀγαπητήν	ἀγαπητόν
Vocative	ἀγαπητέ or ἀγαπητός	ἀγαπητή	ἀγαπητόν

	Plural		
	a-2a	a-1b	a-2c
	Masculine	Feminine	Neuter
Nominative	ἀγαπητοί	ἀγαπηταί	ἀγαπητά (short)
Genitive	ἀγαπητῶν	ἀγαπητῶν	ἀγαπητῶν
Dative	ἀγαπητοῖς	ἀγαπηταῖς	ἀγαπητοῖς
Accusative	ἀγαπητούς	ἀγαπητάς	ἀγαπητά (short)
Vocative	ἀγαπητοί	ἀγαπηταί	ἀγαπητά (short)

ἅγιος, -α, -ον (holy, sacred) ἅγιο/α + case ending

Singular			
	a-2a	a-1a	a-2c
	Masculine	Feminine	Neuter
Nominative	ἅγιος	ἅγια	ἅγιον
Genitive	ἁγίου	ἁγίας	ἁγίου
Dative	ἁγίῳ	ἁγίᾳ	ἁγίῳ
Accusative	ἅγιον	ἁγίαν	ἅγιον
Vocative	ἅγιε or ἅγιος	ἁγία	ἅγιον

Plural			
	a-2a	a-1b	a-2c
	Masculine	Feminine	Neuter
Nominative	ἅγιοι	ἅγιαι	ἅγια (short)
Genitive	ἁγίων	ἁγίων	ἁγίων
Dative	ἁγίοις	ἁγίαις	ἁγίοις
Accusative	ἁγίους	ἁγίας	ἅγια (short)
Vocative	ἅγιοι	ἁγιαι	ἅγια (short)

δίκαιος, -αία, -ον (right, just, righteous) δικαιο/α + case ending

Singular			
	a-2a	a-1a	a-2c
	Masculine	Feminine	Neuter
Nominative	δίκαιος	δικαία	δίκαιον
Genitive	δικαίου	δικαίας	δικαίου
Dative	δικαίῳ	δικαίᾳ	δικαίῳ
Accusative	δίκαιον	δικαίαν	δίκαιον
Vocative	δίκαιε or δίκαιος	δικαία	δίκαιον

Plural			
	a-2a	a-1a	a-2c
	Masculine	Feminine	Neuter
Nominative	δίκαιοι	δίκαιαι	δίκαια (short)
Genitive	δικαίων	δικαίων	δικαίων
Dative	δικαίοις	δικαίαις	δικαίοις
Accusative	δικαίους	δικαίας	δίκαια (short)
Vocative	δίκαιοι	δίκαιαι	δίκαια (short)

ἔσχατος, -η, -ον (last) ἔσχατο/η + case ending

	Singular		
	a-2a	a-1b	a-2c
	Masculine	Feminine	Neuter
Nominative	ἔσχατος	ἔσχατη	ἔσχατον
Genitive	ἔσχατου	ἔσχατης	ἔσχατου
Dative	ἔσχατῳ	ἔσχατῆ	ἔσχατῳ
Accusative	ἔσχατον	ἔσχατην	ἔσχατον
Vocative	ἔσχατε or ἔσχατος	ἔσχατη	ἔσχατον

	Plural		
	a-2a	a-1b	a-2c
	Masculine	Feminine	Neuter
Nominative	ἔσχατοι	ἔσχαται	ἔσχατα (short)
Genitive	ἔσχατων	ἔσχατων	ἔσχατων
Dative	ἔσχατοις	ἔσχαταις	ἔσχατοις
Accusative	ἔσχατους	ἔσχατας	ἔσχατα (short)
Vocative	ἔσχατοι	ἔσχαται	ἔσχατα (short)

καλός, -ή, -όν (good, beautiful, handsome) καλο/η + case ending

	Singular		
	a-2a	a-1b	a-2c
	Masculine	Feminine	Neuter
Nominative	καλός	καλή	καλόν
Genitive	καλοῦ	καλῆς	καλοῦ
Dative	καλῶ	καλῇ	καλῶ
Accusative	καλόν	καλήν	καλόν
Vocative	καλέ or καλός	καλή	καλόν

	Plural		
	a-2a	a-1b	a-2c
	Masculine	Feminine	Neuter
Nominative	καλοί	καλαί	καλά (short)
Genitive	καλῶν	καλῶν	καλῶν
Dative	καλοῖς	καλαῖς	καλοῖς
Accusative	καλοῦς	καλάς	καλά (short)
Vocative	καλοί	καλαί	καλά (short)

παλαιός, -ά, -όν (old, obsolete) παλαιο/α + case ending

	Singular		
	a-2a	a-1a	a-2c
	Masculine	Feminine	Neuter
Nominative	παλαιός	παλαιά	παλαιόν
Genitive	παλαιού	παλαιᾶς	παλαιού
Dative	παλαιῶ	παλαιᾷ	παλαιῶ
Accusative	παλαιόν	παλαιάν	παλαιόν
Vocative	παλαιέ or παλαιός	παλαιά	παλαιόν

	Plural		
	a-2a	a-1a	a-2c
	Masculine	Feminine	Neuter
Nominative	παλαιοί	παλαιαί	παλαιά (short)
Genitive	παλαιῶν	παλαιῶν	παλαιῶν
Dative	παλαιοῖς	παλαιαῖς	παλαιοῖς
Accusative	παλαιούς	παλαιάς	παλαιά (short)
Vocative	παλαιοί	παλαιαί	παλαιά (short)

πρῶτος, -η, -ον (first) πρωτο/η + case ending

		Singular		
		a-2a	a-1b	a-2c
		Masculine	Feminine	Neuter
Nominative	πρῶτος	πρώτη	πρῶτον	
Genitive	πρώτου	πρώτης	πρώτου	
Dative	πρώτῳ	πρώτῃ	πρώτῳ	
Accusative	πρῶτον	πρώτην	πρῶτον	
Vocative	πρῶτε or πρῶτος	πρώτη	πρῶτον	

		Plural		
		a-2a	a-1b	a-2c
		Masculine	Feminine	Neuter
Nominative	πρῶτοι	πρώται	πρῶτα (short)	
Genitive	πρώτων	πρώτων	πρώτων	
Dative	πρώτοις	πρώταις	πρώτοις	
Accusative	πρώτους	πρώτας	πρῶτα (short)	
Vocative	πρῶτοι	πρώται	πρῶτα (short)	

σοφός, -ή, -όν (wise, skillful, clever) σοφο/η + case ending

	Singular		
	a-2a	a-1b	a-2c
	Masculine	Feminine	Neuter
Nominative	σοφός	σοφή	σοφόν
Genitive	σοφού	σοφῆς	σοφού
Dative	σοφῶ	σοφῇ	σοφῶ
Accusative	σοφόν	σοφήν	σοφόν
Vocative	σοφέε or σοφός	σοφή	σοφόν

	Plural		
	a-2a	a-1b	a-2c
	Masculine	Feminine	Neuter
Nominative	σοφοί	σοφαί	σοφά (short)
Genitive	σοφῶν	σοφῶν	σοφῶν
Dative	σοφοῖς	σοφαῖς	σοφοῖς
Accusative	σοφούς	σοφάς	σοφά (short)
Vocative	σοφοί	σοφαί	σοφά (short)

§12.29 Declension-paradigm notation. The declension-paradigm notation for adjectives may be classified in several ways. Some divide on the basis of whether the adjective has a separate form for the feminine or if the masculine and feminine use the same form (*The Morphology of Biblical Greek* by William Mounce, pp. 216-240). The basis on which this grammar notates adjectives is the same basis as nouns: vowel (first and second declension adjectives) and consonantal (third declension adjectives) stems. This notation maintains consistency between nouns and adjectival declensional endings.

§12.3 The Verb EIMI.

Because the Greek verb EIMI usually occurs in predicate constructions, it is prudent to introduce it at this point. Unlike many Greek verbs that have predictable inflectional endings, the verb “to be” in English and Greek is irregular in its forms. Because of its irregular conjugation, the different aspects (present, future, and imperfect) of the verb EIMI will have to be memorized by brute force—but memorize you must!

Present Indicative

listen	Singular		Plural	
1 st person	εἶμι	I am	ἐσμέν	we are
2 nd person	εἶ	you are	ἐστέ	you are
3 rd person	ἐστί(ν)*	he/she/it is	εἰσί(ν)*	they are

*The forms in parentheses are alternative forms because of the movable ν.

Imperfect Indicative

listen	Singular		Plural	
1 st person	ἦμην	I was	ἦμεν (ἦμεθα)*	we were
2 nd person	ἦς (ἦσθα)*	you were	ἦτε	you were
3 rd person	ἦν	he/she/it was	ἦσαν	they were

*The forms in parentheses are (rare) alternative forms.

Future Indicative

listen	Singular		Plural	
1 st person	ἔσομαι	I will be	ἔσόμεθα	we will be
2 nd person	ἔσῃ	you will be	ἔσεσθε	you will be
3 rd person	ἔσται	he/she/it will be	ἔσονται	they will be

§12.3.1 Movable Nū. Notice the two alternative present indicative forms. The ending of 3rd person singular and plural forms sometimes has a -ν added. It is known as the **movable nū**. It does not affect the translation. It was usually inserted at the end of some words which were followed by punctuation marks or which were followed by words beginning with vowels for purposes of euphony, that is, a more pleasant sound in pronunciation.

§12.3.2 Accent. All the present forms of εἶμί are enclitic except for εἶ which always retains its accent. An **enclitic** is a word which, whenever possible, is read closely with the preceding word that has no accent of its own. You will observe the accent dropping off the present forms of εἶμί and causing occasional changes of accentuation in words in front of it. This phenomenon does nothing to the meaning of the words.

The rules for accenting enclitic words are interrelated with proclitics. Therefore, it is best to study them together in a later lesson.

§12.3.3 Finite forms. All the forms above are finite forms of εἶμί. What constitutes a finite verb? It is a verb that is limited (< Latin: *finis*, “end, limit”) in five aspects: to **person** (first, second, and third), **number** (singular and plural), **mood** (indicative, subjunctive, imperative, and optative) **tense** (present, future, imperfect, aorist, perfect and pluperfect), and **voice** (active, middle, and passive). Finite verbs are contrasted with their “infinite” parts, the infinitive and participles that have neither person nor number.

These five aspects of Greek verbs are explained briefly below.

§12.3.31 Person. Person indicates whether the subject of the verb is speaking (first person), is being addressed (second person), or is the one about whom the statement is made (third person). Person is the same in Greek as it is in English.

	Singular	Plural
First Person	I am	we are
Second Person	you are	you are
Third Person	he, she, or it is	they are

Both the second person singular and plural are translated “you”. Modern English has no way of indicating the distinction the Greek is making. Care should be taken, however, to note the distinction.

§12.3.32 Number. Verbs like nouns may be singular or plural. With verbs, the number indicates if the subject of the verb is singular or plural.

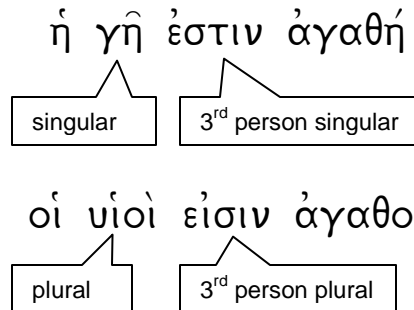

§12.3.33 Tense. Greek verbs express a combination of dimensions of verbal meaning. Greek tenses can express verbal aspect (*i.e.*, the verbal action as a process, undifferentiated whole or as a particular state in a complex situation) and time of action (past, present, or future) in distinct combinations.

§12.3.34 Voice. Voice expresses the relation of the verb’s action to its subject. In an **active** verb, the subject is the doer of the action of the verb, “The dog bit the man”. If the verb is **passive**, the subject receives the action of the verb, “The man was bitten by the dog”. Because copulative verbs like εἰμί indicate a state of being rather than an action, they therefore do not have voice.

§12.3.35 Mood. Mood expresses a relation to reality. For example, the indicative mood states that, or asks whether, a statement is true (from the viewpoint of the speaker or writer). The imperative mood instructs the subject of the verb that an action be made real, “[you] Pick up the book!”

In future lessons, these five aspects are fully explained and illustrated.

§12.3.4 Predicate complements. Copulative verbs do not take a direct object as a transitive verb (“Bill hit the ball”), but a predicate complement, whether a predicate nominative or a predicate adjective. This is the same as in English: “I am he” (predicate nominative), or “Bill is happy” (predicate adjective). **Predicate complements** predicate something about someone

or something. Both nouns and adjectives may be used in predications. The most commonly occurring copulative verb in NTGreek is εἶμί.

Predicate nominative: **θεὸς ἦν ὁ λόγος**
 Translation: the word was God

Predicate adjective: **πιστὸς ὁ θεός**
 Translation: [the] God [is] faithful

As in the predicate adjective example, the verb may be omitted in a predicate sentence; however, it must be supplied in translation in brackets.

§12.3.41 Sentence order. The predicate complement usually follows the copulative verb. For emphasis (as above), however, it may be placed before the verb, or even before the expressed subject of the verb.

§12.3.42 Parsing EIMI. As with nouns and adjectives, it will be helpful to establish a parsing pattern when a Greek verb is parsed. This grammar uses the following order: person, number, tense, voice, mood, and lexical form. The lexical form is the first person singular, present indicative. However, some verbs appear in other forms, a phenomenon that will be explained in a later lesson.

Inflected form: εἶ		Inflected form: ἦσαν
second (2 nd)	Person	third (3 rd)
singular (sg.)	Number	plural (pl.)
present (pres.)	Tense	imperfect (impft.)
X	Voice	X
indicative (ind.)	Mood	indicative (ind.)
εἶμί	Lexical form	εἶμί
“you are”	Translation	“they were”

Remember that since εἶμί is a copulative verb, and therefore predicates a state of being, it does not have voice as transitive and intransitive verbs. This is indicated in the above chart with an “X”. When a copulative verb is parsed, voice is simply omitted.

§12.3.421 Examples of εἶμί parsed. Below are all the inflected finite forms of the verb εἶμί parsed. Study them carefully. After memorizing the present, imperfect, and future forms of this verb, try this exercise: cover the right-hand column with a piece of paper, and then parse the inflected forms in the left-hand column, only uncovering the answer in the right-hand column to check your parsing accuracy.

1.	εἶμί	1 st sg. pres. ind. of εἶμί, “I am”
2.	εἶ	2 nd sg. pres. ind. of εἶμί, “you are”
3.	ἐστί	3 rd sg. pres. ind. of εἶμί, “he/she/it is”
4.	ἐστίν	3 rd sg. pres. ind. of εἶμί, “he/she/it is”
5.	ἐσμέν	1 st pl. pres. ind. of εἶμί, “we are”
6.	ἐστέ	2 nd pl. pres. ind. of εἶμί, “you are”
7.	εἰσὶ	3 rd pl. pres. ind. of εἶμί, “they are”
8.	εἰσίν	3 rd pl. pres. ind. of εἶμί, “they are”
9.	ἦμην	1 st sg. impft. ind. of εἶμί, “I was”
10.	ἦς	2 nd sg. impft. ind. of εἶμί, “you were”
11.	ἦσθα	2 nd sg. impft. ind. of εἶμί, “you were”
12.	ἦν	3 rd sg. impft. ind. of εἶμί, “he/she/it was”
13.	ἦμεν	1 st pl. impft. ind. of εἶμί, “we were”
14.	ἦμεθα	1 st pl. impft. ind. of εἶμί, “we were”
15.	ἦτε	2 nd pl. impft. ind. of εἶμί, “you were”
16.	ἦσαν	3 rd pl. impft. ind. of εἶμί, “they were”
17.	ἔσομαι	1 st sg. fut. ind. of εἶμί, “I will be”
18.	ἔσῃ	2 nd sg. fut. ind. of εἶμί, “you will be”
19.	ἔσται	3 rd sg. fut. ind. of εἶμί, “he/she/it will be”
20.	ἔσόμεθα	1 st pl. fut. ind. of εἶμί, “we will be”
21.	ἔσεσθε	2 nd pl. fut. ind. of εἶμί, “you will be”
22.	ἔσονται	3 rd pl. fut. ind. of εἶμί, “they will be”

§12.4 Adjective Flow Chart

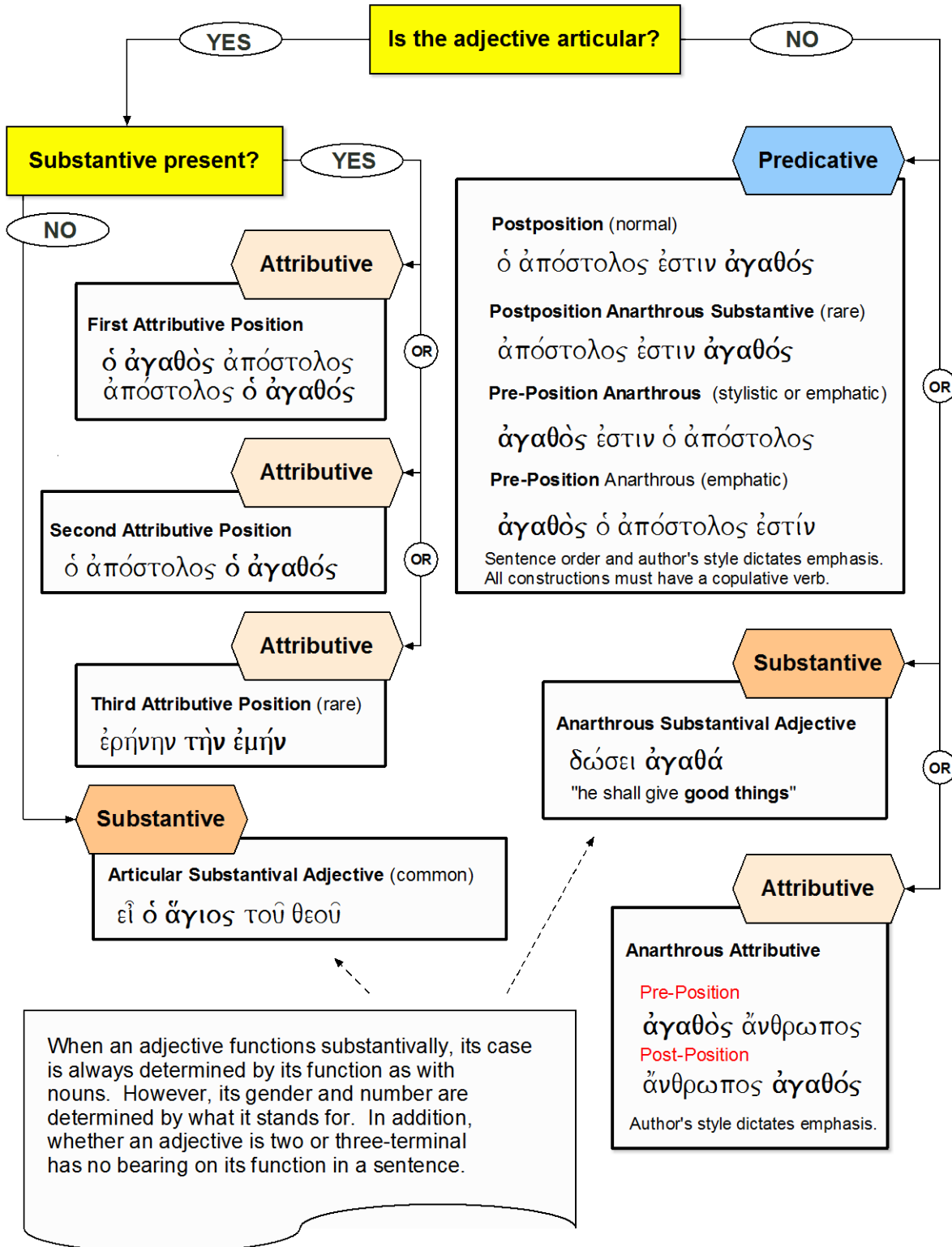

§12.5 Vocabulary Study

Information to be included on adjective flash cards is different from nouns. First, the lexical form is the nominative masculine singular form and not the nominative singular as for nouns. The article is not placed anywhere on the card in connection with the adjective since the adjective is declined in all three genders and not just one gender like most nouns. Finally, the genitive singular is not cited after the masculine singular form.

An example of how information may be placed on flash cards for adjectives is below. More may be added, however, the following essential information must be included.

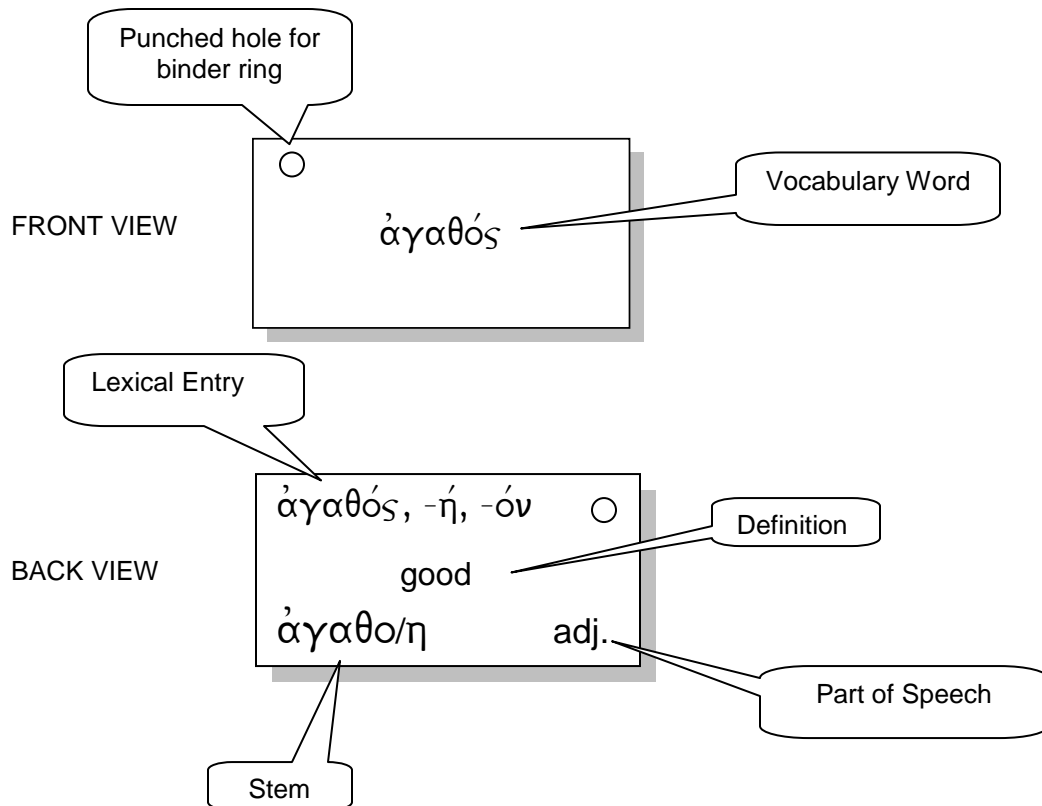

Because there are no fixed rules to predict whether an adjective will have two or three terminations, its lexical entry must identify whether the adjective is a two or three-terminal adjective. As in the example above, adjectives that have a separate feminine inflection are three-terminal. The stem form for a two-terminal adjective would simply be καλο since the feminine forms are identical to those of the masculine.

Vocabulary word	Meaning	Part of Speech
ἀγαθός, -ή, -όν Stem: ἀγαθο/η	good	adjective
	ἀ-γα-θός (a-ga-thós) cf. “Agatha”	
ἀγαπητός, -ή, -όν Stem: ἀγαπητο/η	beloved	adjective
	ἀ-γα-πη-τός (a-ga-pē-tós) cf. ἀγάπη	
ἅγιος, -α, -ον Stem: ἅγιο/α	holy, sacred	adjective
	ἅ-γι-ος (há-gi-os) cf. “hagiolatry” Paul uses this adjective substantivally to address those who belong to the Body of Christ, the Church (cf. Rom. 1:7; 1 Cor. 1:2; 2 Cor. 1:1; Eph. 1:1; Phil. 1:1; Col. 1:2, etc.).	
ἄδικος, -ον Stem: ἄδικο	unjust, unrighteous	adjective
	ἄ-δι-κος (á-di-kos)	
ἀληθινός, -ή, -όν Stem: ἀληθινο/η	true	adjective
	ἀ-λη-θι-νός (a-lē-thi-nós) cf. ἀλήθεια	
ἄλλος, -η, -ο Stem: ἄλλο/η	another	adjective
	ἄλ-λος (ál-los) cf. allomorph, allonym Adjective usually means “another” of the same kind or order. The neuter nominative, vocative, and accusative singular is irregular.	
ἁμαρτωλός, -όν Stem: ἁμαρτωλο	sinful	adjective
	ἁ-μαρ-τω-λός (ha-mar-tō-lós) cf. “hamartiology”	
ἄπιστος, -ον Stem: ἄπιστο	unfaithful	adjective
	ἄ-πι-στος (á-pi-stos) The <i>alpha</i> is actually a prefix. When used, it means “not” or “without”, as in “achromatic” or “asymmetrical” (cf. πιστός).	
διδάσκαλος, -ου, ὁ Stem: διδασκαλο	teacher	noun
	δι-δά-σκα-λος (di-dá-ska-los) n-2a	
δίκαιος, -αία, -ον Stem: δικαιο/α	right, just, righteous	adjective
	δί-και-ος (dí-kai-os) The extended feminine termination is traditionally cited. The final <i>alpha</i> is long; therefore, the accent moves to the penult syllable from the antepenult on the masculine. However, it is accurate to give the lexical form as: δίκαιος, -α, -ον	
εἰμί Stem: εἶ-	I am	verb
	εἶ-μί (ei-mí)	

Vocabulary word	Meaning	Part of Speech
ἕκαστος, -α, -ον Stem: ἑκαστο/α	each	adjective
	ἕ-κα-στος (hé-ka-stos)	
ἔσχατος, -η, -ον Stem: ἑσχατο/η	last	adjective
	ἔ-σχα-τος (é-scha-tos) cf. "eschatology"	
ἕτερος, -α, -ον Stem: ἑτερο/α	another, different	adjective
	ἕ-τε-ρος (hé-te-ros) cf. "heterosexual" The adjective usually means "another" of a different kind or order. Paul uses the adjective as a play on words in Galatians 1:6-7: "I am amazed that you are so quickly deserting Him who called you by the grace of Christ for another (ἕτερον) gospel which is not another (ἄλλο)". In other words, there is only one gospel. Anyone who believes Jesus proclaimed a different gospel than Paul should reread these verses again. Cf. ἄλλος	
ἐχθρός, -ά, -όν Stem: ἐχθρο/α	hostile, hated	adjective
	ἐ-χθρός (e-chthρός)	
ἰσχυρός, -ά, -όν Stem: ἰσχυρο/α	strong	adjective
	ἰ-σχυ-ρός (i-schy-rós)	
καινός, -ή, -όν Stem: καινο/η	new	adjective
	και-νός (kai-nós) cf. "kainite"	
κακός, -ή, -όν Stem: κακο/η	bad, evil	adjective
	κα-κός (ka-kós) cf. "cacophony"	
καλός, -ή, -όν Stem: καλο/η	good, beautiful, handsome	adjective
	κα-λός (ka-lós)	
λοιπός, -ή, -όν Stem: λοιπο/η	remaining, the rest	adjective
	λοι-πός (loi-pós) καὶ τὰ λοιπά means, "and the rest", abbreviated as κ.τ.λ. or as κτλ. This corresponds to the Latin, <i>et cetera</i> , abbreviated as "etc", also meaning "and the rest".	
μακάριος, -α, -ον Stem: μακαριο/α	blessed, happy	adjective
	μα-κά-ρι-ος (ma-ká-ri-os) cf. "macarism"	
μικρός, -ά, -όν Stem: μικρο/α	small, little	adjective
	μι-κρός (mi-krós) cf. "microscope", ὁ μικρόν	

Vocabulary word	Meaning	Part of Speech
μωρός , -ά, -όν Stem: μωρο/α	foolish, stupid	adjective
	μω-ρός (mō-rós) cf. "moron"	
νεκρός , -ά, -όν Stem: νεκρο/α	dead	adjective
	νε-κρός (ne-krós) cf. "necrolatry", "necromancy"	
παλαιός , -ά, -όν Stem: παλαιο/α	old, obsolete	adjective
	πα-λαι-ός (pa-lai-ós) cf. "paleography"	
πιστός , -ή, -όν Stem: πιστ/η	faithful, dependable	adjective
	πι-στός (pi-stós)	
πλούσιος , -ία, -ιον Stem: πλουσιο/α	rich	adjective
	πλού-σι-ος (ploú-si-os) cf. "plutolatry", "plutocratic"	
πονηρός , -ά, -όν Stem: πονηρο/α	wicked, evil, bad	adjective
	πο-νη-ρός (po-nē-rós)	
πρῶτος , -η, -ον Stem: πρωτο/η	first	adjective
	πρῶ-τος (prō-tos) cf. English prefix: "proto-"	
σοφός , -ή, -όν Stem: σοφο/η	wise, skillful, clever	adjective
	σο-φός (so-phós) cf. σοφία, "sophomore"	
τυφλός , -ή, -όν Stem: τυφλο/η	blind	adjective
	τυ-φλός (ty-phlós) cf. "typhlosis"	
φίλος , -ή, -όν Stem: φιλο/η	beloved, dear, devoted	adjective
	φι-λός (phi-lós) cf. "bibliophile"	

Pairing possible antonyms may help to learn this lesson's vocabulary.

ἀγαθός - κακός	ἄπιστος -- πιστός
ἀγαπητός - ἐχθρός	ἔσχατος -- πρῶτος
ἅγιος -- ἁμαρτωλός	καινός -- παλαιός
ἄδικος -- δίκαιος	ἄσοφος* -- σοφός

*This adjective is not part of this lesson's vocabulary list. Its lexical entry is ἄσοφος, -ον.

12

Study Guide

Adjectives

First and Second Declension Adjectives

Exercise One: True or False. Select the correct answer. Be careful, because all the statement has to be correct in order for it to be true.

1. Both in English and Greek, an adjective modifies by describing or limiting as to quality, quantity, or definiteness to nouns, pronouns, or a phrase used as a substantive. True False
2. Many adjectives were originally nouns placed near other nouns to describe or otherwise limit their meaning, and gradually grew into a distinct part of speech. True False
3. Greek adjectives can come before or follow a copulative verb.
True False
4. English adjectives that follow nouns and repeat the meaning of the noun in different words are adjective appositives. True False
5. The inflectional paradigm for the Greek adjective has inflected forms for each of the three genders: masculine, feminine, and unisex.
True False
6. Greek adjectives always reflect the same declensional ending as the noun they modify. True False
7. When an adjective functions adjectivally, it usually agrees with the substantive it modifies in case, gender, and number. True False
8. An adjective in the first attributive position is immediately preceded by the article and both precede the anarthrous substantive. True False
9. An adjective in the second attributive position is immediately preceded by the article and both follow the articular substantive. True False

10. The following example is an example of the fourth attributive position.
True False

ὁ ἀγαθὸς ὁ ἄνθρωπος

11. The third attributive position is rarely found in NTGreek. True False
12. Attributive adjectives may appear in pre-positive and postpositive positions. True False
13. In most instances, the attributive adjective will be articular. True False
14. The adjective agrees with the explicit substantive it modifies in case, gender, and number. True False
15. An adjective functions predicatively only when it meets the following criteria: (1) the adjective is articular, (2) the presence of an explicit or implicit substantive (with or without the article), and (3) the construction includes a transitive verb. True False
16. All the following examples are possible for adjectives in the predicate position. True False

ἀγαθὸς ἐστὶν ἀπόστολος
ὁ ἀπόστολος ἀγαθός
ὁ ἀπόστολος ἐστὶν ἀγαθός
ἀγαθὸς ἀπόστολος

17. NTGreek authors typically used the copulative verb with the predicative adjective construction. True False
18. Unlike the attributive adjective, the predicative adjective agrees with the substantive it modifies in case, gender, and number. True False
19. The predicative adjective construction is more emphatic than the simpler attributive adjective. True False
20. Adjectives function substantival when it performs the function of a substantive. True False

21. The substantival adjective is usually preceded by the article, although not necessarily immediately. True False
22. In Greek, substantival adjectives are considerably more common than in English. True False
23. A distinction between an adjective and a substantive is that a substantive's gender remains constant throughout its inflection, whereas the adjective does not. True False
24. The primary lexical entry for adjectives is its nominative masculine singular form, and not the nominative singular. True False
25. As part of the adjective's lexical entry, its genitive singular form is cited to establish its declension-paradigm. True False
26. The article is not part of an adjective's lexical entry. True False
27. The lexical entry for an adjective cites the type and position of its accent. True False
28. Adjectives that are two-terminal use the masculine-feminine and neuter endings like second declension nouns. True False
29. Adjectives that are three-terminal decline feminine adjectives using forms from the first declension hybrid pattern (n-1c). True False
30. The stem vowel for two-terminal adjectives is *omikron* and follows inflectional patterns of second declension nouns. True False
31. There are not any anarthrous substantival adjectives in NTGreek. True False
32. The verb εἰμί is a finite transitive verb. True False
33. All the present forms of εἰμί are enclitic. True False
34. Verbs belong to conjugations, and nouns declensions. True False
35. Mood as it pertains to verbs expresses a relation to reality. True False

Exercise Two: Adjective Usage. Choose whether the adjectives are attributive, predicate, or substantive.

Example: ἡ ἀγαθή A P **S**

1.	ὁ ἀγαθός	A	P	S
2.	ὁ υἱὸς ἐστὶν ἀγαθός	A	P	S
3.	ἀγαθὸς ἐστὶν ὁ υἱός	A	P	S
4.	ὁ υἱὸς ἀγαθός	A	P	S
5.	ὁ υἱὸς ὁ ἀγαθός	A	P	S
6.	πονηρὰ ἡ καρδία ἐστίν	A	P	S
7.	τὸ ἀγαθόν	A	P	S
8.	ὁ ἀγαθὸς ἄνθρωπος	A	P	S
9.	ἀπόστολοι οἱ ἕτεροι	A	P	S
10.	τῶν ἀποστόλων τῶν ἀγαθῶν	A	P	S
11.	ἀγαθὸς θεός	A	P	S
12.	θεῶ τῷ ἀγαθῷ	A	P	S
13.	ὁ θεὸς ἐστὶν ἀγαθός	A	P	S
14.	πιστὸς ἦν ὁ λόγος	A	P	S
15.	οἱ ἄγγελοι οἱ ἅγιοι	A	P	S
16.	ἡ γῆ ἐστὶν ἀγαθή	A	P	S
17.	ὁ πρῶτος	A	P	S
18.	ὁ νόμος ἅγιος καὶ ἡ ἐντολὴ ἅγια	A	P	S
19.	τὸ σοφόν	A	P	S
20.	τῇ σοφῇ	A	P	S
21.	τῶν παλαιῶν	A	P	S
22.	τοῦ ἀνθρώπου τοῦ ἀγαθοῦ	A	P	S
23.	μακάριος εἶ	A	P	S

Exercise Three: Multiple Choice. Choose the best answer.

1. How can adjectives be identified as to usage?
 - a. function
 - b. declension
 - c. form
 - d. conjugation

2. What are the three degrees of comparison for English adjectives?
 - a. ultima, penult, and antepenult
 - b. acute, grave, and circumflex
 - c. positive, comparative, and superlative
 - d. masculine, feminine, and neuter

3. What kind of adjectives does not permit comparison?
 - a. predicate
 - b. attributive
 - c. absolute
 - d. substantive

4. What is it called when an adjective that functions adjectivally agrees with the substantive it modifies in case, gender, and number?
 - a. inflection
 - b. grammatical concord
 - c. predicative
 - d. cross-declension dissonance

5. Which of the following phrases is an example of an adjective in the second attributive position?
 - a. τὴν ὥραν τὴν πρώτην
 - b. οἱ ἀγαθοὶ ἄνθρωποι
 - c. εἰρήνην τὴν ἐμὴν
 - d. ὁ ἀγαθὸς ὁ ἄνθρωπος

6. Which of the following phrases is an example of an adjective functioning substantival?
- a. διδάσκαλε ἀγαθέ
 - b. τὸν ἅγιον
 - c. ἀγαθὸς ἐστὶν ὁ ἀπόστολος
 - d. ὁ ἀγαθὸς λόγος
7. The lexical entry for a two-terminal adjective is which of the following?
- a. nominative singular
 - b. nominative masculine singular
 - c. nominative plural
 - d. nominative masculine plural
8. The lexical entry for adjectives includes which of the following?
- a. genitive singular form and the article
 - b. the article and the nominative feminine singular form
 - c. nominative masculine singular form and the article
 - d. nominative masculine singular form
9. The proper lexical entry for a three-terminal adjective is which of the following?
- a. ἀγαθός, -ή, -όν
 - b. ἁμαρτωλός, -όν
 - c. ἕτερος, ὁ
 - d. δίκαιος, -αία, ὁ

10. Which of the following is the correct parsing for ἔστέ?
- a. 2nd sg. pres. act. ind. of εἶμί
 - b. 2nd pl. pres. act. ind. of εἶμί
 - c. 2nd pl. pres. ind. of εἶμί
 - d. 3rd pl. impft. ind. of εἶμί
11. Which of the following is the lexical entry for εἶμί?
- a. first person singular, present indicative
 - b. first person singular, present active indicative
 - c. masculine nominative singular
 - d. first person singular, imperfect active indicative
12. Which of the following is the normal sentence order for a predicate complement?
- a. subject, verb, complement
 - b. verb, subject, complement
 - c. complement, subject, verb
 - d. subject, complement, verb
13. Which aspect of the Greek verb expresses a combination of dimensions of verbal meaning?
- a. number
 - b. number and voice
 - c. mood
 - d. tense
14. How does the alpha privative prefix affect words?
- a. negates
 - b. makes it more private
 - c. makes an adjective a noun
 - d. makes a noun an adjective

Exercise Four: Translation. Translate the following phrases and sentences.

1. πιστὸς ὁ θεός. 1 Corinthians 1:9
2. πιστός ἔστιν καὶ δίκαιος. 1 John 1:9
3. Τιμοθέω ἀγαπητῶ τέκνω 2 Timothy 1:2
4. καλὸς ἔση διάκονος Χριστοῦ. 1 Timothy 4:6
5. ὁ νόμος ἅγιος καὶ ἡ ἐντολὴ ἀγία καὶ δικαία καὶ ἀγαθή.
Romans 7:12
6. εἶ ὁ διδάσκαλος τοῦ Ἰσραήλ. John 3:10
7. αἱ ἡμέραι αἱ ἔσχαταί εἰσι πονηραὶ ἡμέραι.
8. μόνω σοφῶ θεῶ Romans 16:27
9. ἕτερον εὐαγγέλιον Galatians 1:6

10. τὰ πρῶτα ἔργα Hebrews 9:15

11. ὁ τοῦ κόσμου σοφός

12. ὁ ἀγρός ἐστὶν ὁ κόσμος. Matthew 13:38

13. καὶ θεὸς ἦν ὁ λόγος. John 1:1

14. εἶμι τὸ Ἄλφα καὶ τὸ Ὡ. Revelation 1:8

15. εἶμι ὁ θεὸς Ἀβραὰμ καὶ ὁ θεὸς Ἰσαὰκ καὶ ὁ θεὸς Ἰακώβ. Matthew 22:32

16. μακάριοί ἐστε. Matthew 5:11

17. τέκνα θεοῦ ἐσμέν. 1 John 3:2

Exercise Five: Parsing. Parse the following inflected forms. Include all essential information, including a proper translation of the inflected form.

	Inflected Form	Parsing
1.	παλαιέ	
2.	πρώτῳ	
3.	διδάσκαλον	
4.	ἔση	
5.	θηρία	
6.	ἀβύσσων	
7.	σοφῆς	
8.	εἶ	
9.	ἐσμέν	
10.	τόν	
11.	ἔσχατα	
12.	πιστῶν	
13.	ἀγαπητῆ	
14.	δίκαιαι	
15.	ἁγίου	
16.	ἁματωλός	
17.	κόσμους	
18.	δῶρα	
19.	μαθηταῖς	
20.	κριταί	